

# Rules for Building Construction or Alteration: Rural 1 Zone

Tasman Resource Management Plan  
(the “TRMP”)

## Summary Guide No. 1

Current: July 2018

The following is a **summary** of Tasman Resource Management Plan (TRMP) provisions for building construction or alteration in the Rural 1 Zone.

The TRMP specifies, through its rules, whether an activity is permitted (meaning you can do it as of right), or whether it requires a resource consent. For this guide, generally only the **Permitted** Activity standards are listed, except where otherwise specified (for example, dwellings and other habitable buildings).

For activities that require resource consent, the TRMP uses RMA prescribed categories that become increasingly more stringent in terms of assessment criteria. The categories used within the relevant TRMP chapters are Controlled, Restricted Discretionary, Discretionary, Non Complying and Prohibited Activities. If you do need a resource consent, check with Council’s duty planner for the level of information you will need to provide with a resource consent application.

A proposed activity may also be subject to additional standards and rules for other aspects of the development (such as access formation and parking requirements). In addition to standards and consents required under the Resource Management Act, the proposed activity may also need building consent, licences and permits under other legislation such as the Building and Health Acts.



### 1. Permitted Activities

Non-habitable buildings and alterations to an existing dwelling are a **Permitted** activity if they meet the following requirements:

- a. The **total area** of all buildings on a site is no greater than:
  - 600m<sup>2</sup> for any site with a net area of up to 4000m<sup>2</sup>; or
  - 600m<sup>2</sup> or 5% of the site area (but not greater than 2000m<sup>2</sup>) for sites larger than 4000m<sup>2</sup>.
- b. **Height** is limited to 7.5 metres above natural ground level but buildings on hills with a ridgeline identified on the planning maps are to be no higher than the level of the ridgeline.

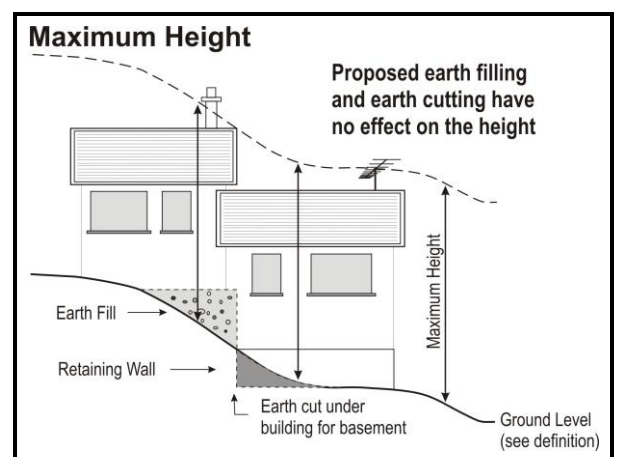

- c. **Building setbacks** are at least:
  - 10 metres from road boundaries and 5 metres from other property boundaries — however a non-habitable building may be set within 5 metres of an internal boundary where the landowner of the property has provided written permission;

- 20 metres from the margins of lakes and from Open Space, Recreation and Conservation zones;
  - 8 metres from the banks of rivers with a bed less than 5 metres wide;
  - 20 metres from the banks of rivers with a bed greater than 5 metres wide;
  - 30 metres from the road boundary for any building forming part or all of a rural selling place;
  - 30 metres from a plantation forest; and
  - 100 metres from a Viewpoint shown on the planning maps.
- d. Where the site adjoins a Residential Zone, buildings must comply with **daylight admission angles** on all boundaries adjoining the Residential Zone. Daylight admission angles are constructed from any point 2.5 metres above ground level on relevant boundaries, then at an angle across the site depending on the direction the boundary faces. For example, the angle is 45 degrees for north-facing boundaries, 35 degrees for east and west-facing boundaries and 25 degrees for south-facing boundaries. No building can project beyond the daylight admission angles, although the TRMP includes exceptions for gable ends and alternatives for a site on a south-facing slope.

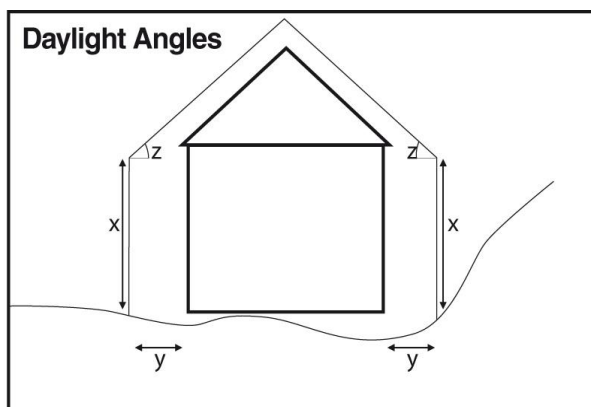

x = 2.5 metres up from any point on side and rear boundaries  
y = distance the external wall is from the property boundary  
z = the daylight angle between 25 and 45 degrees depending on the direction the boundary faces

## 2. Dwellings and Habitable Buildings require Resource Consent

Dwellings and habitable buildings, including sleepouts within the Rural 1 Zone, require resource consent application, as they do not meet the **Permitted** Activity rules. Design and assessment for consent will need to consider the following rules in any consent assessment.

- a. **Dwellings and habitable buildings** have different setbacks from other buildings:
- 30 metres from any **internal boundary**, except where the activity is an alteration to a dwelling, and the setback to the boundary is not thereby reduced; and except where the boundary is to the Residential, Rural Residential or Rural 3 zone where the setback is 5 metres;
  - 130 metres from any building or enclosure that houses poultry that is on an existing lawfully established intensive livestock farm which is a **poultry farm** on or before 30 January 2016, except for habitable buildings located on the same site as the existing lawfully established intensive livestock farm which is a poultry farm;
  - at least 500 metres from a **quarry site** which disturbs the land more than 50m<sup>3</sup> in any 12-month period.
- b. Any **new residential activity** (such as a sleepout or dwelling), if located within 300 metres of a frost protection device that is likely to exceed specified noise limits, is located, orientated and constructed to ensure that bedroom and living rooms achieve an indoor design sound level of 30 dBA  $L_{eq}$  and 45 dBA  $L_{max}$  from permitted noise levels.
- c. **Domestic Water Supply** - A dwelling not connected to a reticulated water supply is supplied with a reliable and potable supply of water (rain, ground or surface) and, where the water is stored on site, there is at least 23,000 litres of storage.
- d. **Fire Risk Management** - A dwelling not connected to a reticulated water supply that has water mains fitted with fire hydrants no more than 135 metres from the dwelling must either be provided with:
- a home fire sprinkler system that is fitted with a reliable year-round supply; or
  - a water supply (either 45,000 litres stored water or a flow of 25 litres per second for 30 minutes) located between 6 and 90 metres from the dwelling and accessible to fire-fighting equipment.
- e. There is an adequate area on site for **domestic wastewater disposal**.

f. A **sleepout** (a detached bedroom that may have a bathroom but no kitchen or cooking facilities) is no more than:

- 20 metres from any dwelling (including a minor dwelling); and
- 36m<sup>2</sup> in area.

There is a maximum of two sleepouts associated with any principal or second dwelling that is not a minor dwelling.

### 3. Stormwater Management

All buildings and construction activities manage and dispose of stormwater on site. Any stormwater discharge complies with the Permitted Activity rules within section 36.4 of the TRMP.

### 4. Special Area Rules

Rural 1 Zone buildings must also meet all of the relevant Chapter 18 Special Area rules, for example:

- Quarry Area** - A new dwelling or residential activity requires a resource consent application.
- Residential Activity Restriction Area** - Dwellings or residential activities require resource consent application if they are at least 500 metres from a working quarry which disturbs the land more than 50m<sup>3</sup> in any 12-month period.
- Coastal Risk Area** – Only relocatable and non-habitable buildings are permitted.
- Coastal Environment Area** - Extensions to existing buildings are permitted if they do not increase the ground floor area by more than 50%; reduce the existing setback from MHWS; or increase the existing height. Alterations not complying with the above or new buildings within 200 metres of MHWS will require resource consent.  
Resource consent conditions will include a requirement that the external colourings be recessive.
- Slope Instability Risk Area** - Construction or extension to a building is permitted if a geotechnical report:
  - states the building will not be subject to damage from slope instability nor contribute to damage on adjoining properties;
  - specifies any measures to be carried out to avoid damage; and

- identifies that any earthwork has an average vertical height or depth less than or equal to 1 metre.

f. **Fault Rupture Risk Area** – Construction or alteration of a habitable building is permitted if a geotechnical/earthquake risk report identified the surface position of the active fault and buildings are set back specified distances from it (see TRMP Chapter 18.13 for details).

### 5. Flood Hazards

Provisions in Rule 16.10.3.1 prohibit:

- a. the construction or relocation of buildings over 15m<sup>2</sup> in floor area on any berm land; and
- b. habitable buildings over 10m<sup>2</sup> in floor area within 20 metres of a stopbank that is more than 1 metre high, or within 50 metres of a stopbank that is more than 2 metres high.

### 6. Relocated Dwellings

If any dwelling to which the above provisions apply is a relocated dwelling, then Rule 16.8.3.1 or 16.8.3.2 also applies and resource consent will be required. Council will require a refundable bond in addition to other charges to ensure the dwelling's exterior is reinstated within a specified time in order to maintain the visual amenity.

### 7. National Environment Standard for Contaminated Soil (NES-CS)

The NES-CS contains rules that require resource consent if soil is shown to have levels of contamination above that suitable for a site that will be used for the development of a dwelling and associated residential use.

Council holds records of established orchards in the 1970s that may have been exposed to persistent pesticides such as lead, arsenic, copper and DDT resulting in pesticide residues in the soil. Before any land with areas of soil contamination is used for a residential activity, Council will require specialised soil testing as part of any resource consent application. Soil contamination may also occur by other means such as historic sheep dip sites and surrounding holding paddock, fertiliser storage sites, airstrips and bulk bins and fuel tanks. These may need resource consent and soil testing as set out in the NES-CS. Please seek Duty Planner advice.

## 8. Development and Financial Contributions

A development contribution is payable in accordance with the Development Contribution Policy set out in the Council's Long Term Plan and created under the Local Government Act 2002.

The development contribution is required to help fund District roads and infrastructural services other than reserves and community facilities.

A financial contribution for reserves and community services is payable in accordance with the TRMP on all building development other than a first dwelling on a title. You will need to refer to Section 16.5 of the TRMP for full details of the financial contributions that are payable and whether any limitations or exceptions apply.

**This guide is a summary of TRMP provisions only. Do not rely on this guide to make decisions about your property. Other conditions may apply. Please see the TRMP for full details or seek advice from Council staff at one of the Tasman District Council offices.**

### Tasman District Council

**Email** [info@tasman.govt.nz](mailto:info@tasman.govt.nz)

**Website** [www.tasman.govt.nz](http://www.tasman.govt.nz)

**24 hour assistance**

### Richmond

189 Queen Street

Private Bag 4

Richmond 7050

New Zealand

**Phone** 03 543 8400

### Murchison

92 Fairfax Street

Murchison 7007

New Zealand

**Phone** 03 523 1013

### Motueka

7 Hickmott Place

PO Box 123

Motueka 7143

New Zealand

**Phone** 03 528 2022

### Tākaka

78 Commercial Street

PO Box 74

Tākaka 7142

New Zealand

**Phone** 03 525 9972